

blind spot assist system

Installation & Operation Manual
v1.0

www.letsyada.com

Thank you for purchasing the Blind Spot Assist System. This system was designed to give additional convenience when driving or operating your vehicle. The system helps detect obstacles in your vehicle's blind spots. All parts needed to install and operate the system are included in this package.

Winplus North America
820 South Wanamaker Avenue, Ontario, CA 91761
customercare@winplususa.com
www.winplususa.com

Winplus Europe
Unit 4, Two Counties Estate, Falconer Road,
Haverhill, Suffolk CB9 7XZ, U.K.
info@winplus-europe.com
www.winplus.net

Winplus Asia
Suites 6-11, 7th Floor, Corporation Park,
11 On Lai Street, Shatin, N.T., Hong Kong
info@winplus.net
www.winplus.net

Winplus Australia
Unit 2, 991 Mountain Hwy Boronia,
Victoria, Australia, 3155
customercare@winplus.com.au
www.winplus.com.au

Winplus New Zealand
Griffiths Equipment
22-24 Olive Road, Penrose, Auckland, New Zealand
web@griffiths.co.nz
www.types.co.nz

▶ Contents

- WARRANTY / LIABILITIES
- PRIOR TO INSTALLATION
- PACKAGE CONTENT
- TECHNICAL SPECIFICATIONS
- INSTALLATION INSTRUCTIONS
- OPERATIONS
- CUSTOMER SERVICE / CONTACT US
- FCC / ICC

WINPLUS NORTH AMERICA

LIMITED WARRANTY

Winplus North America warrants, to the original purchaser, that its products are free from defects in material and workmanship for 1 year from the date of original purchase. Where permitted by law, Winplus North America's liability shall be limited to that set forth in this limited express warranty. This limited express warranty shall be the exclusive remedy of the purchaser and Winplus North America makes no other warranty of any kind aside from the limited express warranty stated above.

NOTE: Warranty only applies for North American customers or purchases made in the North America.

CONDITIONS OF WARRANTY

If during the 1 year warranty period your new product is found to be defective, Winplus North America will repair such defect, or replace the product, without charge for parts or labor subject to the following conditions:

1. All repairs must be performed by Winplus North America.
2. All warranty claims must be accompanied by a copy of the sales receipt or bill of sale.
3. The equipment must not have been altered or damaged through negligence, accident, improper operation, or failure to follow the product instructions for installation, use, or care.

4. The replacement of parts is excluded from the warranty when replacement is necessary due to normal wear and tear.
5. Repair or replacement parts supplied by Winplus North America under this warranty are protected only for the unexpired portion of the original warranty.
6. This is a "repair or replace" warranty only, and does not cover the costs incurred for the installation, removal or reinstallation of the product, or damage to any mobile phone device or vehicle.

OWNER'S RESPONSIBILITIES:

Winplus North America will make every effort to provide warranty service within a reasonable period of time. SHOULD YOU HAVE ANY QUESTIONS ABOUT SERVICE RECEIVED OR IF YOU WOULD LIKE ASSISTANCE IN OBTAINING SERVICE, PLEASE CALL TOLL FREE 1.866.294.9244 DURING REGULAR BUSINESS HOURS MONDAY THROUGH FRIDAY 9:00 AM TO 5:00PM.

NOTE: Toll Free # is for North America Customers ONLY. See Customer service section for customer contact numbers for other regions/offices.

In order to provide you with the proper warranty service, we request that you adhere to the following procedure:

1. Include a copy of your sales receipt or bill of sale with your unit when it is returned for warranty service.
2. If it is necessary to return your product for service, please return it securely packed, preferably in the original shipping box, and freight and insurance prepaid to the following address:

ATTN: CUSTOMER CARE PRODUCTS RETURNS
820 South Wanamaker Avenue,
Ontario, CA 91761

3. Please include a detailed explanation of the problem you are having.
4. If your product is found by Winplus North America to have a defect in material or workmanship, within the warranty period, it will be repaired or replaced at no charge and returned to you prepaid.

Winplus North America makes no other warranty of any kind aside from the limited express warranty stated herein.

DISCLAIMER OF WARRANTIES, INCLUDING WARRANTY OF MERCHANTABILITY AND WARRANTY OF FITNESS FOR PARTICULAR PURPOSE: EXCEPT AS SPECIFICALLY SET FORTH HEREIN, NO WARRANTY OR REPRESENTATION, EXPRESS OR IMPLIED, IS MADE AS TO THE BLIND SPOT ASSIST SYSTEM. EXCEPT AS EXPRESSLY SET FORTH HEREIN, WINPLUS NORTH AMERICA AND/OR ITS AFFILIATES EXPRESSLY DISCLAIMS, WITHOUT LIMITATION, ANY STATUTORY WARRANTIES AND ALL IMPLIED WARRANTIES, INCLUDING ANY IMPLIED WARRANTY OF MERCHANTABILITY OR FITNESS FOR A PARTICULAR PURPOSE.

Winplus North America and/or its affiliates does not guarantee or promise that the user of our Blind Spot Assist System will not be in an accident or otherwise not collide with an object and/or person. Our Blind Spot Assist System are not intended in any way to be substitute for careful and cautious driving or for the consistent adherence to all applicable traffic laws and motor vehicle safety regulations.

The Blind Spot Assist System is not intended to be a substitute for rearview mirrors or for any other motor vehicle equipment mandated by law. Even when properly installed, our Blind Spot Assist System has a limited field of vision and do not provide a comprehensive view of the rear area of the vehicle. You should always look around outside your vehicle and use your mirrors to confirm rearward clearance and that your vehicle can back up safely.

Winplus North America and/or its affiliates are not responsible for a user's intended or actual use of the Blind Spot Assist System. In no event shall Winplus North America and/or its affiliates have any liability for any losses (whether direct or indirect, in contract, tort or otherwise) incurred in connection with the Blind Spot Assist System, including but not limited to damaged property, personal injury and/or loss of life. Neither shall Winplus North America and/or its affiliates have any liability for any decision, action or inaction taken by any person in reliance on the Blind Spot Assist System, or for any delays, inaccuracies and/or errors in connection with the Blind Spot Assist System and its functioning.

Winplus North America and/or its affiliates shall have no responsibility or liability for damage and/or injury resulting from accidents occurring with vehicles having the Blind Spot Assist System installed, and Winplus North America and/or its affiliates, the manufacturer, distributor and seller shall not be liable for any injury, loss or damage, incidental or consequential, arising out of the use or intended use of the product.

WINPLUS EUROPE

LIMITED WARRANTY

Winplus warrants, to the original purchaser, that its products are free from defects in material and workmanship for 12 months from the date of original purchase. Where permitted by law, Winplus liability shall be limited to that set forth in this limited express warranty. This limited express warranty shall be the exclusive remedy of the purchaser and Winplus makes no other warranty of any kind aside from the limited express warranty stated above.

OWNER'S RESPONSIBILITIES:

In order to provide you with the proper warranty service, we request that you adhere to the following procedure:

1. Include a copy of your sales receipt or bill of sale with your unit when it is returned for warranty service.
2. If it is necessary to return your product for service, please return it securely packed, preferably in the original shipping box, and freight and insurance prepaid to the following address:

ATTN: WINPLUS PRODUCTS RETURNS

**Unit 4, Two Counties Estate, Falconer Road,
Haverhill, Suffolk CB9 7XZ, UK**

3. Please include a detailed explanation of the problem you are having.
4. If your product is found by Winplus to have a defect in material or workmanship, within the warranty period, it will be repaired or replaced at no charge and returned to you prepaid.

Winplus makes no other warranty of any kind aside from the limited express warranty stated herein.

WINPLUS AUSTRALIA / HONG KONG

LIMITED WARRANTY

This Yada product is warranted against faulty workmanship for a period of 2 years from date of purchase. Liability is limited to replacement of the product and claims for associated or consequential loss or damage will not be accepted. Warranty is void and does not apply if the product has been damaged or rendered faulty by accident, abuse, misuse, incorrect application or if the product has been modified or tampered with. Proof of purchase is required to validate warranty claims. If this product is faulty, simply return it to the place of purchase with your receipt for a replacement product. No refunds or credits will be issued. Replacement is limited to a Yada product of the same or similar model.

► Prior To Installation

Read all the installation instructions carefully before installing the product. Improper installation will void manufacturer's warranty. The installation instructions do not apply to all types of vehicles, and are written as guidelines to assist in installing the system.

Consult an experienced technician if you are not comfortable installing the product. You can also contact Winplus at **866.294.9244** to speak to one of our installation specialist if you have any specific questions regarding Blind Spot Assist System.

BEFORE using the Blind Spot Assist System, please read the following safety information. ALWAYS use the Blind Spot Assist System as outlined here.

⚠ WARNING:

- A failure to read and follow these warnings and instructions may result in a serious accident, including damaged property or a serious injury, including loss of life.
- The Blind Spot Assist System is designed as an aid to the driver in detecting large objects to help avoid damaging the vehicle. However, you, the driver, must use it safely and properly. Use of the Blind Spot Assist System is not a substitute for safe, proper and legal driving.
- Never change lane or operate the vehicle while looking only at the display. You should always check behind and around the vehicle when changing lane just as you would if the vehicle did not have the Blind Spot Assist System. Always make sure your intended path is clear. If you operate a vehicle while looking only at the display, you

may hit a vehicle, pedestrian, bicyclist, child, pet or other object resulting in injury or death.

- Never depend on the Blind Spot Assist System entirely when operating a vehicle. The object distance varies on the speed of the vehicle and is different from various conditions. Actual distance of the objects differs because of the angle of the sensors. Use the inside mirror or glance over your shoulder to properly judge distances to other objects.
- The Blind Spot Assist System is an aid to drivers but is limited. Always use your own eyes to confirm the vehicle's surroundings. Always check behind and all around the vehicle visually and with mirrors before proceeding.
- The area covered by the Blind Spot Assist System is limited. The Blind Spot Assist System does not sense objects that are below the bumper, underneath the vehicle, or objects out of the sensor's field of view. The sensor and display operation may vary according to vehicle orientation or road conditions.
- The Blind Spot Assist System is not intended for use during longer driving maneuvers or backing into potential crossing traffic or pedestrians. Crossing traffic or pedestrians may be approaching outside of the sensor's field of view.
- Be sure to check the sensor's position and mounting angle before each use.
- Make sure the trunk, hatch, or backdoor is completely and securely closed when backing up and operating the vehicle.
- If the back of the vehicle is hit, the position and mounting angle of the Blind Spot Assist System may change.

- When washing the vehicle with high-pressure water, be sure not to spray directly into the sensor. Otherwise, water may enter the sensor unit causing water condensation, malfunction, fire or an electric shock.
- Do not strike the sensors. It is a precision instrument. Otherwise, it may malfunction or cause damage resulting in a fire or an electric shock.
- This product will only monitor obstacles that are within the field of view of the sensors. Thus, it is imperative that the sensors should be kept clean and unobstructed, and should be mounted so that its field of view includes the blind spot area behind your vehicle.
- Distracted driving is dangerous.
- Adhere to all applicable traffic laws and motor vehicle regulations applicable to the device.
- Consult local laws and regulations for any restrictions on installation or use.
- Never allow children to play with the device. Small parts may be a choking hazard.

Package Content



Display



Control Box



LED Warning Lights



Sensors



LED Extension



Hole Saw



Wiring Harness



Strips

⚠ CAUTION: Keep away from reach of children may cause serious injury.

▶ Technical Specifications

Operation Voltage: DC 10-16V

Operation Temperature: -20~70°C

Sensor Horizontal Detection Angle: 120°

▶ Installation Instructions

⚠ IMPORTANT: To ensure proper installation, it is highly recommended for this unit to be installed by a professional.

These instructions do not apply to all types of vehicles. They are meant only as a general guide due to the large number of vehicle makes and models. For vehicle specific questions, contact your vehicle's manufacturer.

Consult your local motor vehicle laws on the use of this product to be sure it is permitted.

WARNING:

- Through installation of the Blind Spot Assist System you should be sure not to degrade the safety of any system or device on your vehicle, including Federal Motor Vehicle Safety Standards.
- Improper installation and wiring of the Blind Spot Assist System may damage the vehicle's electrical system, including vital vehicle computer and operating systems. That could lead to an accident or fire, causing property damage and/or serious personal injury. It is highly recommended to seek professional installation advice from a qualified auto electrician or, in the alternative, to have the installation performed by a qualified auto electrician.

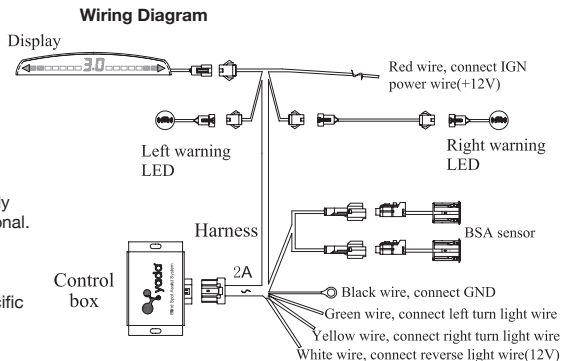

Connect power wire (Red)

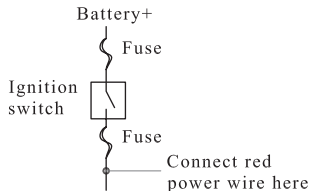

NOTE: Power wire must be controlled by ignition ON/OFF.

Connect left & right turn light wire (Green & Yellow)

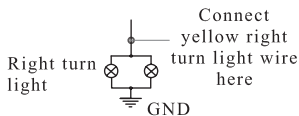
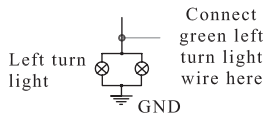

Connect reversing light wire (White)

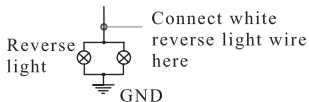

Connect GND (2 Sites)

Connect the ground ring (Black Wire) to a metal part on vehicle body.

Installation

The following provides proper mounting instructions.

NOTICE: Please ensure that the display is secured and mounted where it would NOT obstruct any OEM vehicle safety features. In an event of an accident, manufacturer is not responsible for bodily injury caused by the display being a projectile.

CAUTION: Ensure display monitor location will not obstruct your vision while driving.

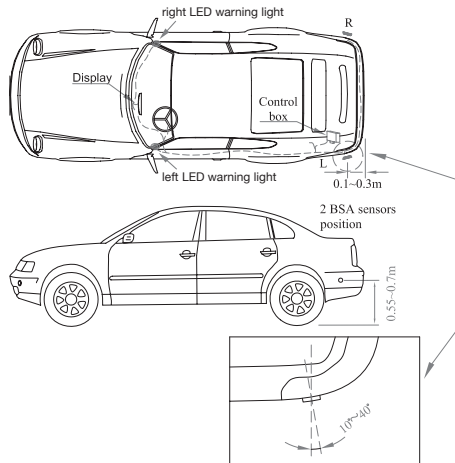

- There are “L” & “R” labels on wiring harness, please connect sensor to corresponding connector
- Please confirm the sensor “UP” side faces upward and the installation height is high enough
- Please make sure that the wiring harness is fixed well and far away from vent-pipe
- Please remove burrs and flash from the hole, make the hole fit for sensor, not too tight or loose, otherwise the system should be abnormal
- The connector of the control box should face ground to prevent water
- Clip the two warning LEDs into the plastic weatherstrips on the A pillar

LED Display



Operations

NOTE: If the unit is installed as outlined, it should ONLY function when the Left and Right turn signals are activated:

Activate/Deactivate Left Sensors:

- To Activate turn your left turn signal On
- The unit will beep
- The Left LED Warning lights will blink when there is an obstacle on the vehicle's left blind spot.
- The display will show the distance of the obstacle from the left blind spot sensor
- To deactivate turn your left turn signal Off

Activate/Deactivate Right Sensors:

- To Activate turn your right turn signal On
- The unit will beep
- The Right LED Warning lights will blink when there is an obstacle on the vehicle's right blind spot.
- The display will show the distance of the obstacle from the right blind spot sensor
- To deactivate turn your right turn signal Off

⚠ WARNING: Do not solely rely on the Blind Spot Assist System. Always practice safe driving habit. Always do a visual check of your vehicle's surrounding before turning or switching lanes.

DISPLAY SETTING

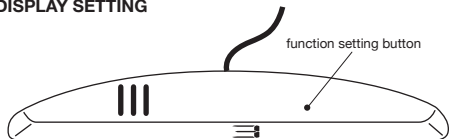

OPERATION	MODE	DISPLAY
Press and hold the function setting button for 1-2 seconds	Volume High	3
	Volume Middle	2
	Volume Low	1
	Volume Off	0
Press and hold the function setting button for 3-4 seconds	Turning Alarm Switch On	C1
	Turning Alarm Switch Off	C0

SAFE OPERATING TIPS

- Do not scratch the sensor when cleaning dirt or snow from the cover.
- The sensor has a water resistant construction. Do not detach, disassemble or modify it. This may cause incorrect operation. Sensor is water resistant but not waterproof.
- Do not submerged sensor in water, which can cause internal damage.
- If the temperature changes rapidly, such as when hot water is poured on the vehicle in cold weather, the system may not operate normally. The system can withstand the effects of rain, snow, and inclement weather.

- If dirt, rain or snow attaches to the sensor, the system may not clearly sense objects. If water droplets, snow or mud adhere to the sensor lens, rinse with water and wipe with a dry cloth.
- Do not use alcohol, benzene or thinner to clean the sensors. This will damage the sensors. To clean the sensors, wipe with a clean a cloth dampened with mild cleaner diluted with water and then wipe with a dry cloth.
- The system is only designed to help detect obstacles in the vehicle's blind spots. WINPLUS is not responsible for damages on the system or the vehicle if used for other purposes.
- ALWAYS engage Parking/Emergency/Hand Brakes of the vehicle when testing the system.
- The system is designed to ADD safety and protection. The device was NOT designed to replace other safe driving habits. Double checking and looking around before performing vehicle maneuvers is STILL the safest way.
- Do not paint over the sensor because it will affect the degrade the sensitivity or damage the system completely.

SAFETY AROUND AND BEHIND OTHER VEHICLES

Using the blind spot assist system is not enough to completely overcome a vehicle's blind spot. Many preventable injuries and deaths occur in driveways or parking lots when drivers do not see children, pets, or others near their vehicles. Here are a few safety tips that will help you to avoid a backover accident.

- Walk completely around your vehicle before getting in. Check for kids, toys, and pets before entering the vehicle and starting the engine.
- Know where children are. Have children stand in a place where they are in full view.
- Be aware of young children. Young children are small and hard to see.
- Parents, caregivers and all adults need to be vigilant in supervising children, especially when children are in the yard, driveway or parking lot playing near parked cars.
- Roll down your window so you will be able to hear what is happening outside your vehicle.
- Owners of SUVs, trucks, and vans need to take extra care to avoid hitting or running over a child.
- Teach children to move away from a vehicle whenever it is started.

Customer Service / Contact Us

For questions or issues regarding the product, please visit www.letsyada.com or contact Winplus in your area/region to speak to our customer service representative:

Winplus North America	Tel.: 866-294-9244
	Tel.: 909-752-3074
Winplus Europe	Tel.: 44-1440-713888
Winplus Australia	Tel.: 61-3-9720-4143
Winplus New Zealand	Tel.: 64-9-5254575
Winplus Asia	Tel.: 852-2798-8932

You can also contact us online by visiting www.winplus.com for more information about the product.

IF YOU ARE EXPERIENCING ANY ISSUES WITH THE PRODUCT DURING OPERATION, DO NOT RETURN THE PRODUCT TO THE STORE. CONTACT WINPLUS DIRECTLY FOR INSTRUCTIONS ON HOW TO RETURN/EXCHANGE THE PRODUCT.

Federal Communication Commission Interference Statement

This equipment has been tested and found to comply with the limits for a Class B digital device, pursuant to Part 15 of the FCC Rules. These limits are designed to provide reasonable protection against harmful interference in a residential installation.

This device complies with Part 15 of the FCC Rules. Operation is subject to the following two conditions: (1) This device may not cause harmful interference, and (2) This device must accept any interference received, including interference that may cause undesired operation.

FCC Caution: Any changes or modifications not expressly approved by the party responsible for compliance could void the user's authority to operate this equipment.

IMPORTANT NOTE**FCC Radiation Exposure Statement:**

This equipment complies with FCC radiation exposure limits set forth for an uncontrolled environment. End users must follow the specific operating instructions for satisfying RF exposure compliance.

This device must not be operating close to power substation.

IC Statement

Operation is subject to the following two conditions:

1. This device may not cause interference and
2. This device must accept any interference, including interference that may cause undesired operation of the device.

IMPORTANT NOTE:**IC Radiation Exposure Statements:**

This equipment complies with IC radiation exposure limits set forth for an uncontrolled environment. End users must follow the specific operating instructions for satisfying RF exposure compliance.



WINPLUS

NORTH AMERICA	820 South Wanamaker Avenue, Ontario, CA 91761	Tel: 909-752-3074 Fax: 310-496-2740
EUROPE	Unit 4, Two Counties Estate, Falconer Road, Haverhill, Suffolk CB9 7XZ, U.K.	Tel: 44-1440-713888 Fax: 44-1440-713889
AUSTRALIA	Unit 2, 991 Mountain Hwy Boronia, Victoria, Australia, 3155	Tel: 61-3-9720-4143 Fax: 61-3-9720-4165
NEW ZEALAND	22-24 Olive Road, Penrose, Auckland, New Zealand	Tel: 64-9-5254575 Fax: 64-9-5256817
ASIA	Suites 6-11, 7th Floor, Corporation Park, 11 On Lai Street, Shatin, N.T., Hong Kong	Tel: 852-2798-8932 Fax: 852-2795-0241

© 2011 Winplus North America Inc. All Rights Reserved. Winplus, the logo design, and Yada are trademarks or registered trademarks of Winplus North America Inc.